

IN0125CE/01

DOUBLE SURFACE LIGHTING

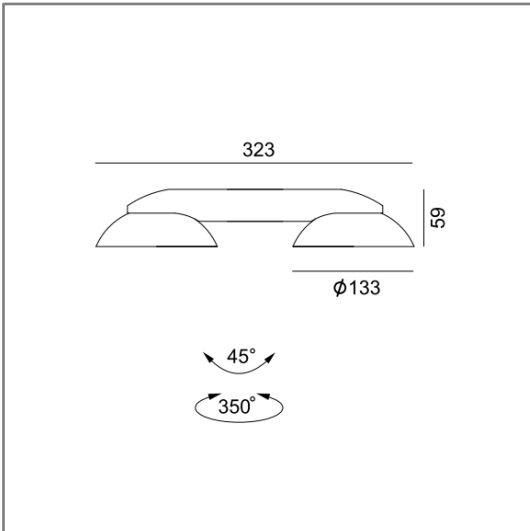

DESCRIPTION:

Double surface lighting, adjustable and dimmable.

TECHNICAL SPECIFICATIONS

Type:	Surface indoor lighting
IP classification:	IP 20
Light source:	led 2x15 watts CRI: 90
Voltage:	220VAC Driver included 700mA
CCT:	3000 K
Beam:	50°
Warranty:	2 years

DIMENSIONS

Length:	323 mm
Width:	133 mm
Height:	59 mm

